

# THE EFFECT OF DIESEL FUEL MIXTURE AND CAMELINA OIL ESTER ON THE PROCESS OF FUEL INJECTION IN TRACTION ENGINE

**Stanisław Orliński**

*Academy of Business in Radom, Faculty of Technical Sciences  
Kolejowa Street 22, 26–600 Radom, Poland  
e-mail: walorl@wp.pl*

**Piotr Orliński, Marcin K. Wojs**

*Warsaw University of Technology, Institute of Vehicles  
Narbutta Street 84, 02–524 Warsaw, Poland  
e-mail: p.orlinski@simr.pw.edu.pl, marcin.wojs@simr.pw.edu.pl*

## **Abstract**

*This paper presents the results of comparative research on basic physical and chemical properties of pure diesel fuel and two types' mixtures of Camelina oil ester (Camelina oil ester content of the mixture was 10% and 15%) and diesel fuel. Application of these mixtures has different physicochemical properties to power supply diesel engine, made it possible to detect existing differences in the injection process (pumping and spraying). The analysis of the injection process has been defined through experimental graphs of the fuel pressure in injection line and registered height of the needle injector. With the knowledge of these two fast-changing engine parameters and load–velocity conditions, there were calculated: fuel flow speed from nozzle, range and fuel spray disintegration time and the average critical diameter of the droplets.*

*In the final part of the article it was shown, that the fuel with different physicochemical properties has a significant impact on the injection process. There were also made a comparative assessment of the suitability test compounds for use in service.*

**Keywords:** fuel plant, process of injection, engine test bench diesel engine

## **1. Introduction**

A growing number of compression ignition engine enforces survey and placing on the market an increasing number of different alternative fuels that have a significant impact on energetic, economic, and mainly ecological indicators of engines work [1, 2].

When internal–combustion engine is powering with biofuel blends with diesel it should be aware that its use reduces power import and consumption of diesel oil. Liquid biofuels should also meet the criteria imposed hydrocarbon motor fuels.

The most important requirements for alternative fuels and liquid biofuels at the same time are [6]:

- occurrence in sufficiently large quantities,
- the cost of production and distribution comparable with conventional fuels,
- no need to implement the complex and costly design changes in engines,
- safety of use engines,
- easy storage and biodegradability,
- low toxicity of the fuel and its combustion products.

Injection and combustion processes are complex, periodically repeated, fast response processes taking place inside the cylinder piston of an engine. One of the quite easily obtained and reliable

sources of information on processes of fuel injection and combustion are graphs: the fuel pressure in the injection, the injector needle lift and cylinder pressure [7, 8].

The use of fuels with different physico-chemical properties to the motor power supply ignition and study its impact on the rates of operation requires high accuracy to provide reliable results of the injection process, the disintegration spout of fuel and its combustion [9].

Solutions to this problem are sought, inter alia, the use of alternative fuels produced in a plant-based oil and their esters. Fuel plant has different physico-chemical properties as compared to hydrocarbon fuels. This causes differences in the process of stamping and fuel atomization as well as the process of combustion in the cylinder [7].

## 2. Research objective

The aim of the study was to assess the impact of diesel oil (ON) and two mixtures of the composition by volume: L-10 (90% ON and 10% camelina ester) and L-15 (85% ON and 15% ester of camelina) on the fuel injection process.

During the test engine has been operated at the maximum volume of fuel (and the two characteristic rotational speeds of the engine crankshaft) and the factory settings regulators.

## 3. The test stand, physical and chemical properties of fuel and a description of test methods

Perkins engine 1104C-E44T with direct fuel injection of Bosch VP-30 injection pump is used primarily as a source of drive of traction engines. Outside the EU and the U.S. is also used in cars.

The research was conducted on a typical built by BN-74/1340-12 and PN-88/S-02005 engine test bench [3].

The choice of fuel supply to the engine due to their availability on the market and taking into account the physical and chemical properties that have a significant impact on the process of fuel injection, ie its density, viscosity and surface tension.

Selected physical and chemical properties of the tested fuels affecting the fuel injection process is shown in Tab. 1. The Fig. 1 shows a block diagram of test stand.

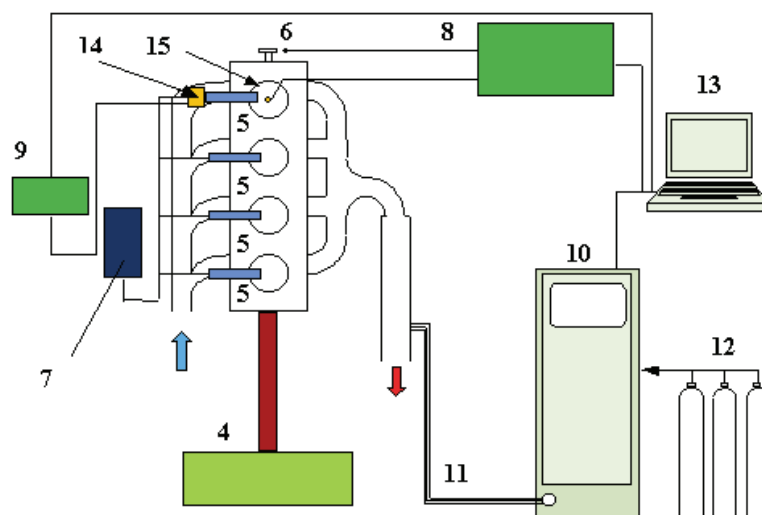

Fig. 1. Block diagram of test stand: 1 – Engine PERKINS 1104C-E44T, 2 – air inlet, 3 – exhaust; 4 – brake Schenck, 5 – Delphi fuel injectors, 6 – recorder crank angle; 7 – Bosch VP30 injection pump, 8 – complex system AVL IndiSmart; 9 – sensor signal amplifier, 10 – gas analyzer AVL CEB II, 11 – way heated, 12 – a set of reference gases, 13 – measuring computer

In the middle of preparing external characteristics of velocity for the engine speed  $n=1400$  rpm (speed of the maximum torque) and  $n=2000$  rpm (speed of the maximum effective power) were

recorded: fuel consumption, fuel pressure the injection pipe, the pressure in the combustion chamber and the stroke of needle injector.

Tab. 1. Selected physical and chemical properties tested fuels affect fuel injection process [10]

PARAMETER	Diesel oil (ON-100%)	L10 (90% ON + 10% ester of camelina)	L15 (85% ON -15% ester of camelina)
Density at 15°C [kg/m <sup>3</sup> ]	835.4	841	848
Viscosity at 40°C [mm <sup>2</sup> /s]	2.64	3.26	3.40
The calorific value [MJ/kg]	43.2	42.5	42.2

Indicator diagrams were removed using a measurement system with sensors piezoelectric AVL hallmarked statically and dynamically in conditions similar to the actual conditions of Perkins engine's work [5].

Using the measured values were determined:

- the pressure in the injection pipe,
- injector needle lift,
- the pressure in the combustion chamber.

After preliminary examination of indicator diagrams were determined: the pressure difference  $\Delta p$  between the pressure in the injector  $p_{w.max}$  and the pressure in the cylinder  $p_{c.max}$  [5]:

$$\Delta p = p_{w.max} - p_{c.max}, [\text{MPa}], \quad (1)$$

where:

$p_{w.max}$  – averaged maximum fuel injection pressure, [MPa],

$p_{c.max}$  – average maximum pressure in the combustion chamber, [MPa].

Range fuel stream depended on: the pressure difference in the well injector and cylinder pressure  $\Delta p$ , the density of the medium in the cylinder  $\rho_g$  and fuel density  $\rho_p$  and the diameter of the pinhole sprayer  $d_o$ . The outflow velocity of the fuel stream from the injector  $u_p$  (in the exhaust nozzle cross-section) was calculated from the equation [4]:

$$u_p = \mu \sqrt{\frac{2\Delta p}{\rho_p}} \quad [\text{m/s}], \quad (2)$$

where:

$\Delta p$  – difference fluid pressure before the nozzle holes and the pressure center, to which fuel is injected, [MPa],

$\rho_p$  – density of the fuel, [kg/m<sup>3</sup>],

$\mu$  – hydrodynamic influence coefficient depends on the design of the injector.

Calculating the average, critical droplet diameter  $d_{kr}$  for the examined fuel carried out according to the formula proposed by Sauter [4]:

$$d_{kr} = \frac{\sigma We_{kr}}{\rho_g u_p^2} \quad [\mu\text{m}], \quad (3)$$

where:

$\sigma$  – surface tension, [N/m],

$\rho_g$  – the density of the gaseous medium, [kg/m<sup>3</sup>],

$We_{kr}$  – the critical Weber number, [m/s],

$u_p$  – the flow rate of fuel flow from the injector, [m/s],

Time calculated from the flow of fuel from the nozzle to the jet break time  $t_f$  can be calculated

from the equation [4]:

$$t_r = \frac{29 \rho_p d}{(\rho_g \cdot \Delta p)^{1/2}} \text{ [ms]}, \quad (4)$$

where  $d$  – diameter nozzle – 0.32 mm [3].

By Hiroyasu penetration depth can be determined [4]:

$S_1$  – the range of primary fuel stream,

$S_2$  – secondary range jet fuel.

For  $t \leq t_r$ :

$$S_1 = 0.39 \left( \frac{2 \Delta p}{\rho_p} \right)^{1/2} t \text{ [mm]}. \quad (5)$$

For  $t > t_r$ :

$$S_2 = 2.95 \left( \frac{2 \Delta p}{\rho_g} \right)^{1/4} (d \cdot t)^{1/2} \text{ [mm]}. \quad (6)$$

#### 4. Graphical comparison of test results

Figure 2 shows a comparison of the maximum fuel pressure in the injector  $P_{w,max}$  for used fuel and at the speed of the engine crankshaft  $n=1400$  rpm and  $n=2000$  rpm.

Figure 3 shows the initial flow rate, fuel flow from the injector  $U_p$  m/s for two rotational speeds of the engine, i.e.  $n=1400$  rpm and  $n=2000$  rpm.

Figure 4 shows the mean droplet diameters  $d_{kr}$   $\mu\text{m}$  formed by the discharge of fuel from the nozzle hole of constant cross-through, designated by Sauter for two rotational speeds of the speeds of the engine crankshaft, i.e.  $n=1400$  rpm and  $n=2000$  rpm.

Figure 5 shows a comparison of fuel streams decay time  $t_r$  ms for two rotational speeds of the engine crankshaft, i.e.  $n=1400$  rpm and  $n=2000$  rpm.

Figure 6 shows a comparison of the instantaneous penetration stream  $S_1$  mm for  $t \leq t_r$  at  $n=1400$  rpm and at  $n=2000$  rpm.

Figure 7 shows the instantaneous penetration of the jet (secondary)  $S_2$  mm for the engine speed  $n=1400$  rpm and for  $n=2000$  rpm.

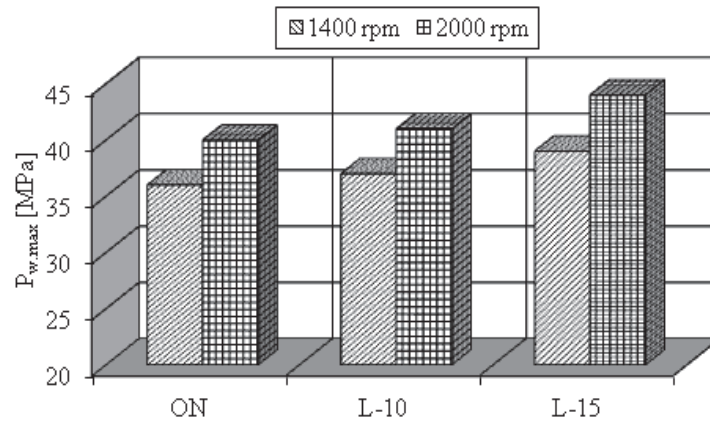

Fig. 2. Comparison of the maximum fuel pressure in the injector  $P_{w,max}$  for the rotational speed of the engine crankshaft  $n=1400$  rpm and  $n=2000$  rpm

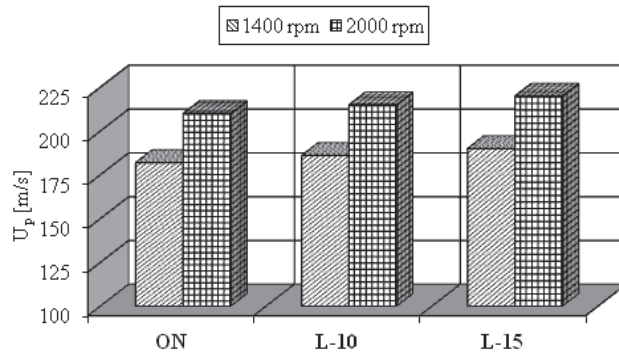

Fig. 3. Comparison of the initial flow rate from the fuel injector  $U_p$  for the rotational speed of the engine crankshaft  $n=1400$  rpm and  $n=2000$  rpm

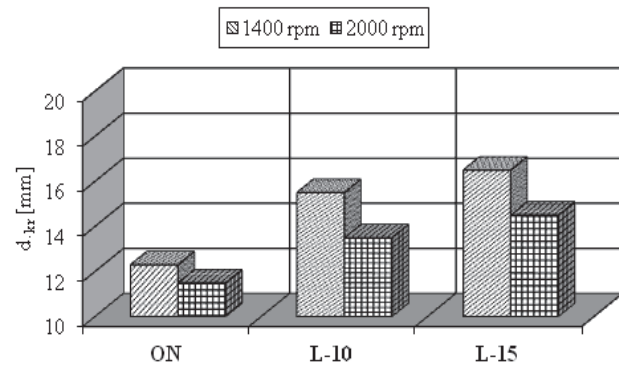

Fig. 4. Critical comparison of average droplet diameter  $d_{kr}$  for the rotational speed of the engine crankshaft  $n=1400$  rpm and  $n=2000$  rpm

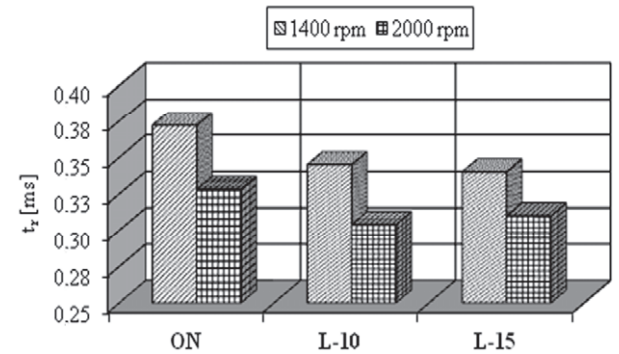

Fig. 5. Comparison of disintegration times of fuel streams  $t_r$  for the two engine speeds  $n=1400$  rpm and  $n=2000$  rpm

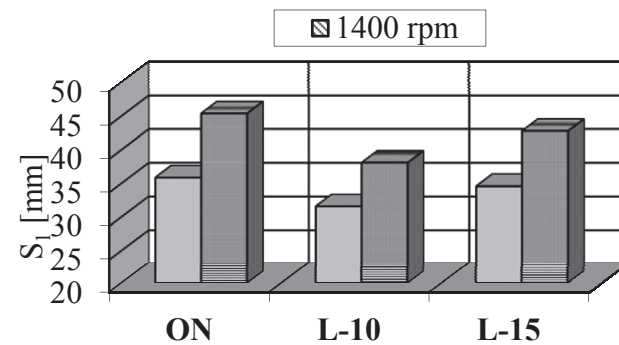

Fig. 6. Comparison of the initial instantaneous fuel stream penetration  $S_l$  for  $t \leq t_r$  and for two engine speeds  $n=1400$  rpm and  $n=2000$  rpm

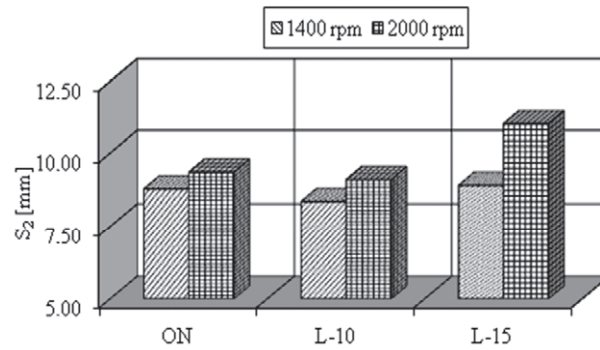

Fig. 7. Comparison of instantaneous penetration of secondary stream  $S_2$  for  $t > t_r$  and for two engine speeds:  $n=1400$  rpm and  $n=2000$  rpm

## Conclusions

Based on the results obtained from the study can draw the following conclusions:

1. The highest average maximum fuel pressure in the injector  $P_{w,max}$  showed a mixture of L-15, and the lowest pressure occurred for hydrocarbon fuel ON (diesel oil) both the crankshaft rotational speed  $n=1400$  rpm and  $n=2000$  rpm. The absolute percentage difference between fuels, L-15 and ON is between 3-10%. This difference is due to the compressibility and variable density and viscosity of the tested fuels (Fig. 2).
2. Initial speed fuel injected  $U_p$  are the most fuel L-15, and the smallest of the fuel ON both the crankshaft rotational speed  $n=1400$  rpm and  $n=2000$  rpm. The absolute percentage difference between the two is, of 3-8%, which was due to the different densities and viscosities of fuels and compressibility (Fig. 3).
3. Research of average diameter of fuel droplets  $d_{kr}$ , have shown that smaller diameters and fuel ON at a speed of  $n=2000$  rpm and  $n=1400$  rpm are the most fuel L-15. The absolute percentage difference between the two is, of 21-28%. This is due to changes in engine load, which affects the fuel pressure in the injector and the density, viscosity and surface tension (Fig. 4).
4. Comparison of the stream disintegration times of fuel droplets  $t_r$  in the combustion chamber found that there are times for a less fuel L-10 and L-15 and are comparable both at speed  $n=1400$  rpm and  $n=2000$  rpm. Larger disintegration times are on the fuel supply to ON. Absolute percentage differences between the used fuel is about 10%. Due to the different size of the fuel pressure in the injector depending on the load and different density, viscosity and surface tension (Fig. 5).
5. The range of fuel streams  $S_1$  ( $t \leq t_r$ ) for all subjects at the crankshaft rotational speed  $n=1400$  rpm and  $n=2000$  rpm fuel consumption is higher for ON and the smallest for fuel L-10 and L-15, which are almost comparable. Absolute percentage differences between the fuels used are from 6-8%. The reason for this is the different size of the counter in the cylinder and the fuel pressure in the injector depending on engine load and varying density, viscosity and surface tension (Fig. 6).
6. The range of fuel jets  $S_2$  ( $t > t_r$ ) for all subjects at the crankshaft rotational speed  $n=1400$  rpm is comparable. However, when  $n=2000$  rpm range jet fuel is the largest for the L-15 and the smallest for fuel L-10 and ON, which are almost comparable. Absolute percentage differences between the fuels used are from 20-25%. This is due to the different size of the counterpressure cylinder and the fuel pressure in the injector depending on the engine load, and a different density, viscosity and surface tension (Fig. 7)
7. It is appropriate to continue the research on the evaluation of the impact of the motor fuels both the mineral and vegetable on economic, energy and environmental indicators of the engine.

8. When assessing the economic aspect of the use of vegetable oil esters and their mixtures of hydrocarbon fuels is advisable to reduce the cost of production and distribution, so that prices of these fuels were comparable to those of hydrocarbon fuels.

### **Acknowledgement**

This paper was developed on the basis of the research results obtained within the author's own research project No. N N504 701340.

### **References**

- [1] Ambrozik, A., *Analiza cyklu pracy czterosuwowych silników spalinowych*, Monografie, Studia, Rozprawy. M-16, Wydaw. Politechniki Świętokrzyskiej, Kielce 2010.
- [2] Ambrozik, A., Ambrozik, T., Orliński, P., Orliński, S., *Wpływ zasilania silnika Perkins 1104C mieszaniną oleju napędowego z dodatkiem etanolu na jego wskaźniki pracy*, Logistyka 3/2011, s. 37-44, 2011.
- [3] Dokumentacja techniczna stanowiska badawczego. Wydział Samochodów i Maszyn Roboczych. Politechnika Warszawska, Warszawa 2012.
- [4] Kowalewicz, A., *Wybrane zagadnienia samochodowych silników spalinowych*, Wydawnictwo Politechniki Radomskiej, Radom 2002.
- [5] Kruczyński, S., Orliński, P., Orliński, S., *Wpływ składu paliwa mikroemulsyjnego węglowodorowo-estrowo-etanolowego na wybrane parametry procesu spalania w silniku o zapłonie samoczynnym*, Journal of KONES, Powertrain and Transport, Vol. 16, pp. 195-202, 2009.
- [6] Merkisz, J., Pielecha, I., *Alternatywne paliwa i układy napędowe pojazdów*, Wydawnictwo Politechniki Poznańskiej, Wydanie I, Poznan 2004.
- [7] Orliński, P., *Wybrane zagadnienia procesu spalania paliw pochodzenia roślinnego w silnikach o zapłonie samoczynnym*, Instytut Naukowo Wydawniczy SPATIUM, Radom 2013.
- [8] Orliński, S., *Wpływ zasilania silnika rolniczego Perkins 1104C-44 paliwami estrowo-etanolowymi na wybrane parametry procesu wtrysku i spalania w aspekcie ekologicznym*, Logistyka 3/2012, pp. 1761-1768, 2012.
- [9] Orliński, S., Orliński, P., *Wpływ zasilania silnika o zapłonie samoczynnym różnymi paliwami na proces wtrysku paliwa*, Logistyka 6/2008, tekst na CD, 2008.
- [10] Świadectiono jakości paliw emulsji paliwowych, Zakład Produktów Naftowych, WMTiW, UTH, Radom 2013.

