

## RELATION OF MOTION RESISTANCE TORQUE AND FRICTION TORQUE IN THE FOUR STROKE ENGINE

**Antoni Iskra, Maciej Babiak, Jarosław Kaluźny**

*Poznan University of Technology  
Institute of Combustion Engines and Transport  
Piotrowo Street 3, 60-965 Poznań, Poland  
phone: +48 61 665 25 11, 665 20 49, 665 27 05, fax: +48 61 665 22 04  
e-mail: antoni.iskra@put.poznan.pl,  
maciej.babiak@interia.pl, jaroslaw.kaluzny@put.poznan.pl*

### **Abstract**

*Friction resistance identification is indispensable to determine the results of engine modifications which goal was to improve the engine mechanical efficiency. Unfortunately measurement of the friction torque is very difficult to realize because in the total motion resistance torque of the combustion engine the friction torque is only a small part. Resistance torque connected with compression of working medium and also at higher engine speeds with inertia resistance is much higher than friction torque. As a result of research made on the engine test bed the course of resistance connected with realization of the thermodynamic cycle were defined. Sufficient accuracy of these courses allows making an attempt to evolve friction resistance signal from global resistance signal. In the paper comparison of the total motion resistance with results of friction resistance computer simulations for hydrodynamic lubrication of piston-cylinder liner kinematic assembly will be made. It is worth to emphasize that movement resistance researches were made at the serial engine with only slight modifications, which considerably restricts the possibility of diversified engine working conditions influence in relation to the actual engine. Further researches on complete movement resistance simulation of the combustion engine are intended to be realized in order to determine the realizability and probable range of desirable friction losses reduction. Promising results will allow designing the competitive engine relative to present tendencies of "ECOMATIC" engine operation system which was proposed for the first time by Volkswagen.*

**Keywords:** *combustion engine, friction losses, global motion resistance torque*

### **1. Introduction**

It is assumed that friction losses in the combustion engine are caused in 50% by journal bearings, 25% by piston rings and also 25% by piston side surfaces. In such approximation friction losses of the valve train and some other mechanisms are omitted. In real engine friction losses division can be much different from quoted above percentages. The simplest verification of these is numerical simulation programs based on the hydrodynamic lubrication theory [1]. Apart from complexity of these programs their suitability should be always verified by test bed studies. In the paper complementary results of the laboratory researches and computer simulations are presented.

### **2. Components of the engine friction resistance**

Developed by authors of this paper computer programs are based on the hydrodynamic lubrication theory and allow to evaluate the instantaneous values of the friction torque generated on engine crankshaft by:

- upper sealing piston ring,
- lower sealing piston ring,
- piston scraper ring,
- piston skirt.

Obtained results are presented on Fig. 1-4.

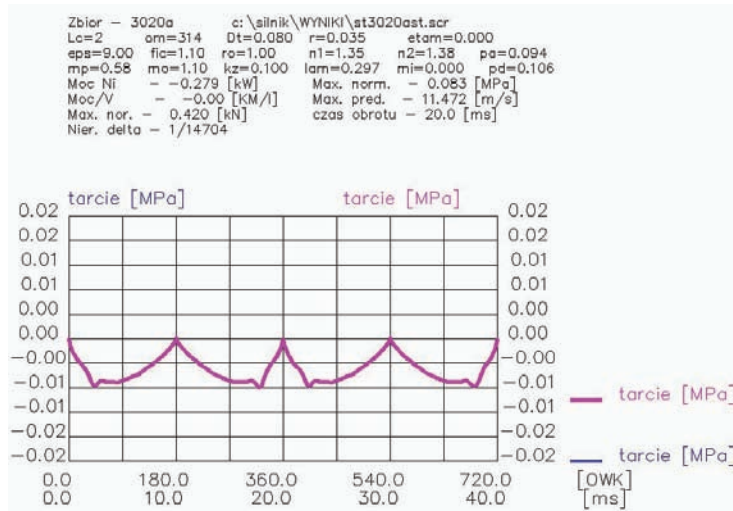

Fig. 1. Friction losses course – represented by specific tangent force – generated by upper piston sealing ring in the following stokes of the reciprocating engine

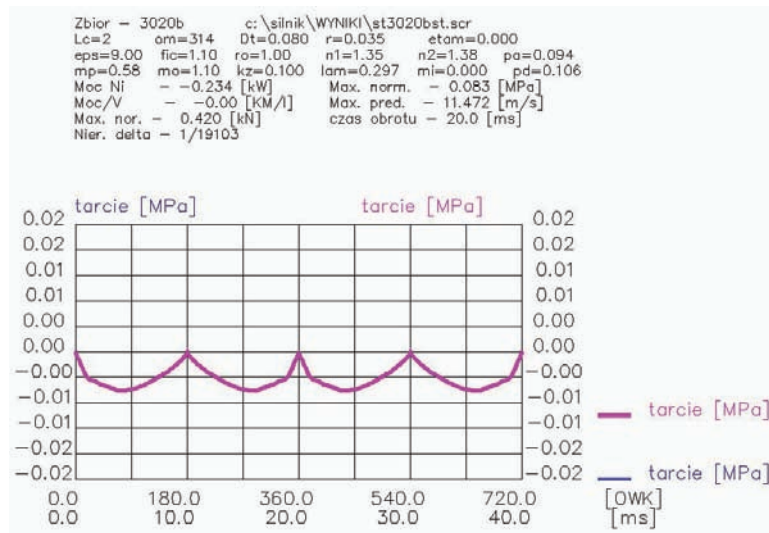

Fig. 2. Friction losses course generated by lower piston sealing-scraper ring in the following stokes of the reciprocating engine

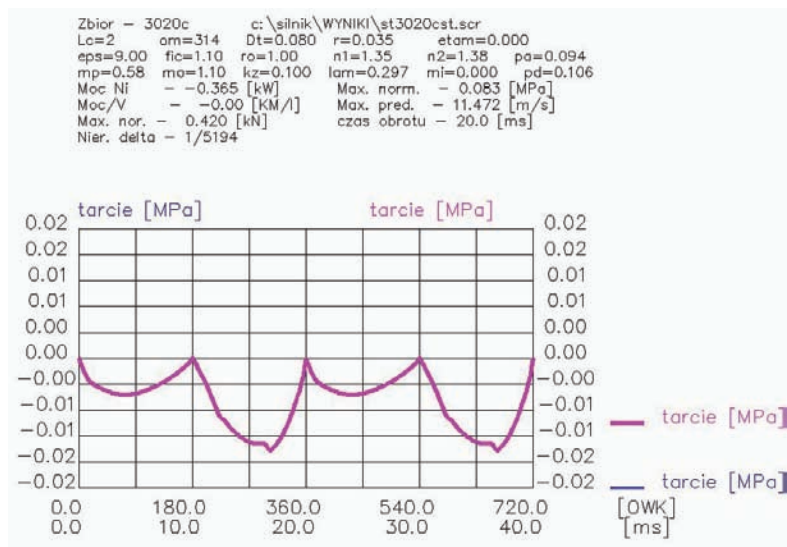

Fig. 3. Friction losses course generated by piston scraper ring in the following stokes of the reciprocating engine

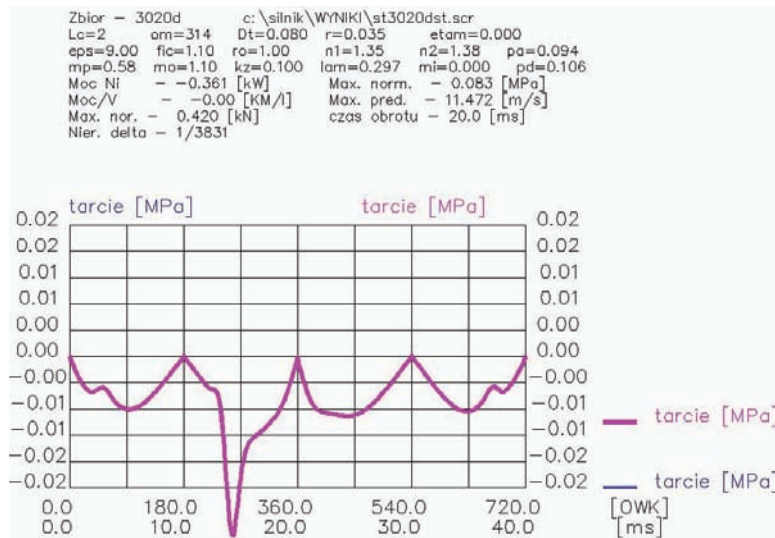

Fig. 4. Friction losses course generated by piston skirt in the following strokes of the reciprocating engine

The friction losses are expressed by tangent force related to the cylinder area so the friction losses torque is the product of the specific tangent force, cylinder area and crank radius. The adopted units of friction losses – [MPa] – allow comparing engines of different type and sizes, for example marine engine with car engine.

Presented on figures 1 - 4 computer simulation results of the friction losses concern 170A.046 engine of CINQUECENTO 700 passenger car. Above graphs basic engine working parameters, for which the simulations were made, are presented. Because of the paper character conditions where friction forces are very high were purposely assumed. Such situation takes place during the engine start when lubricating oil temperature is low.

### 3. The test stand

On Figure 5 crank mechanism of the 170A.046 engine mounted on test stand is presented. On these test stand measurements of the global torque which come from friction losses, gaseous forces and inertia forces were made.

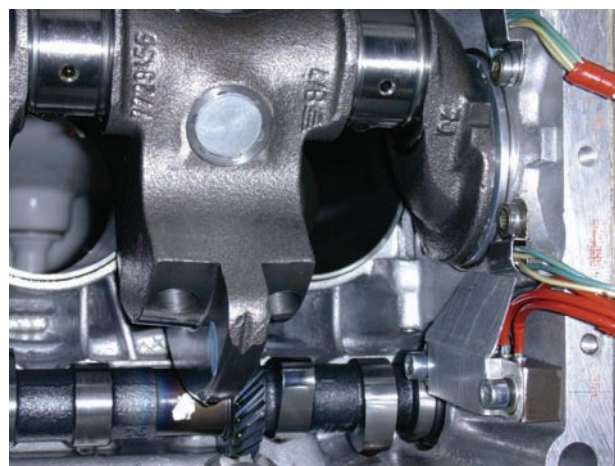

Fig. 5. The crank mechanism of the 170A.046 engine which was used in laboratory researches

The main difficulty is to separate from global torque the friction losses torque which is the difference of global torque and of the gaseous and inertia total torque. In every engine working conditions both mean values of the gaseous forces and the inertia forces are much higher than

friction forces. The results of coupling torque measurements when the combustion engine is combined to an electric machine are shown on Fig. 6.

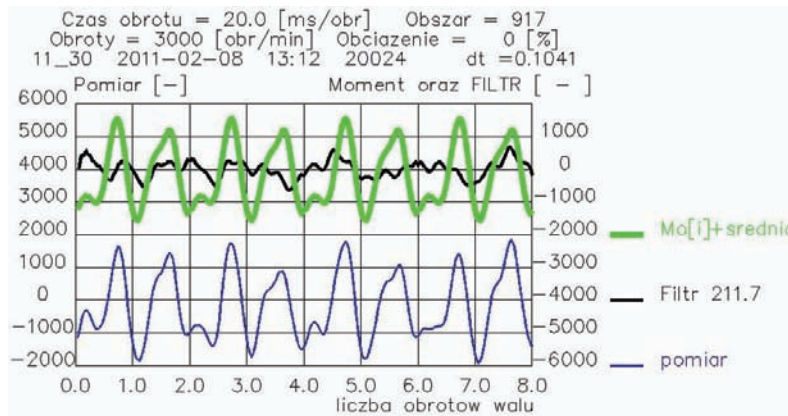

Fig. 6. The coupling torque of the 170A.046 engine with electric motor combination – blue line, results corrected by subtracting the torsional vibration torque – green line, torsional vibration torque – black line

It shows that coupling torque course is not exactly repeatable during engine working cycle. The main reason of this fact is the torsional vibration of the coupling. Therefore it was decided to estimate the course of torsional vibration torque and subtract it from measured coupling torque. The estimation of the torsional vibration torque was made on the base of the equivalent model shown on Fig. 7.

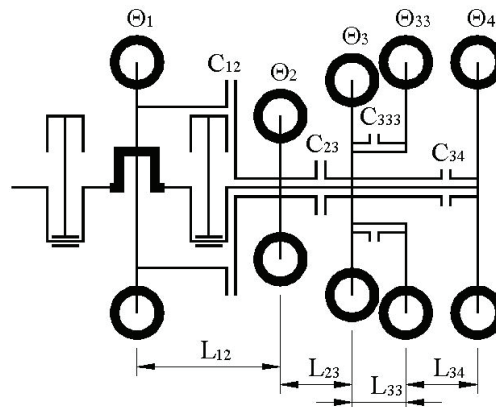

Fig. 7. Equivalent model of the combustion engine and electric machine coupling

On Figure 6 the final result of made correction is represented by green line course. It can be easily noticed that after correction the course of tangent force is repeatable in accordance with cycles of the straight two cylinder engine.

#### 4. Comparison of the global gaseous force torque and inertia torque course with specific friction forces torque

Figure 8 presents the results of computer simulation that allows determining global torque course and friction torque course which is the sum of quantities presented on Fig. 1-4.

For the simulation the same parameters as in Fig. 5 were adopted.

According to presented results of test stand and computer simulation researches the blue line course on Fig. 5 should be different from the violet line course on the Fig. 7 by the value of friction forces. But it can be noticed that the differences are quite substantial. It is special matter because simulated friction force values – blue line on Fig. 7 – are much less than the sum of gaseous and inertia forces – violet line.



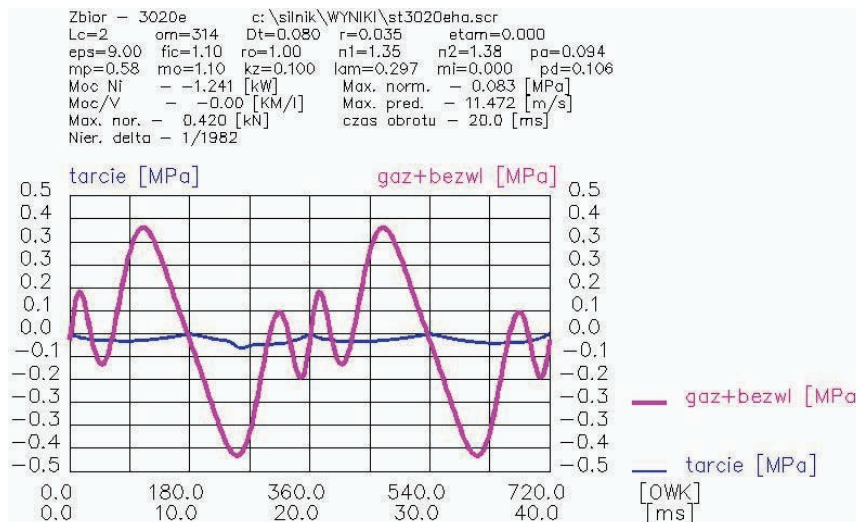

Fig. 8. Computer simulation results of global torque caused by gaseous and inertia forces – violet line, specific friction torque – blue line

## 5. Summary and conclusions

In the paper only some parts of comprehensive researches with use of the test stand and computer simulations are presented. These researches goal is to determine the internal friction torque of the combustion engine by subtracting the sum of gaseous and inertia torque from the global torque that loads the crankshaft. Obtained results allow formulating the following conclusions:

1. Identification of the internal friction torque of the combustion engine based on the torque that is transmitted to the receiver is very difficult because the values of the friction force are usually the smallest among other torques that load the crankshaft.
2. The simulation of gaseous and inertia forces is relatively easy to make by suitable procedures of computer program but determining the additional torsional proper vibration torque of the coupling needs further researches because its value is comparable to the value of engine internal friction force that is being searched.

## References

- [1] Iskra, A., *Studium konstrukcji i funkcjonalności pierścieni w grupie tłokowo-cylindrowej*, Wydawnictwo Politechniki Poznańskiej, Poznań 1996.