

SIMULATION STUDIES OF HYBRID POWERTRAIN FOR URBAN VEHICLES

Andrzej Lechowicz, Andrzej Augustynowicz

*Opole University of Technology
Department of Road and Agricultural Vehicles
Mikołajczyka Street 5, 45-271 Opole, Poland
tel.: +48 77 4498446, fax: +48 77 4499928
e-mail: a.lechowicz@po.opole.pl, a.augustynowicz@po.opole.pl*

Abstract

The powertrain of an urban vehicle was subjected to detailed simulations. This study was conducted with the aim of getting to know the operating principle, verification of assumptions adopted during its design and determination of most effective control procedures to be applied with regard to its powertrain. However, the most important aspect involved the aspect of the power distribution between the engines, electrical machine and vehicle wheels in the particular operating modes of the powertrain. A study was conducted in the MATLAB/Simulink environment with the purpose of finding a configuration of an electrical machine coupling with a combustion engine that offers the greatest advantages in terms of the range of the speed ratio, demanded performance of the electrical machine and maximum power output. The simulations indicated that control of the speed ratio of the vehicle could be gained by application of an electrically controlled planetary gear. The range of the transmission ratio is relative to the ratio of the planetary gear, speed range of the combustion engine as well as electrical machine. The efficiency of the battery charging in the hybrid mode is mostly relative to the operating point of the engine. The optimization of the process of power generation by the electrical machine requires that the operating point of the engine be maintained at a range at which its high performance is guaranteed.

Keywords: *hybrid drive, electrically controlled planetary gear, integrated control*

1. Introduction

The diversity of the solutions applied in hybrid vehicles requires that the engineers working the field need continuously to follow the literature concerned with the design and control of such systems [3, 4, 8]. The efficiency of a hybrid drive is mostly relative to its design and the applied control system. The works dealing with the control of hybrid powertrains primarily focus on the electrical machine, which assists the combustion engine during acceleration and recovers the energy of braking, depending on the system design. The conclusion from such studies is often that the electrical machine should be activated as often as possible. However, the authors in this work mainly focus on the application of an electrical for speed conversion to decide on the transmission ratio and control the power flow between the combustion engine and vehicle wheels [1, 2, 8, 9].

2. Algorithm of powertrain control

This article reports the results of a study into a powertrain based on a simple planetary gear with two degrees of freedom, which differs from a traditional powertrain in considerable ways. A diagram of this system is presented in Fig. 1. This system consists of a planetary gear, combustion engine (ICE), electrical machine which is responsible for the gear change, a control system and batteries. The combustion engine is coupled with a carrier through a gear G_1 . The sun wheel is coupled directly with the shaft in the electrical machine. The power output from the two power sources is transmitted onto the wheels from the ring gear through a gear G_2 . To achieve the separation of both power sources, the system includes two additional brakes (B_1 and B_2) to

disengage the carrier or the sun wheel in the planetary gear. As one of the wheels is blocked, the planetary gear acts as a single-stage transmission with a constant gear ratio. In the powertrain including a planetary gear discussed in this article, the electrical machine is responsible for the control of the speed ratio. By adequate control of the angular velocity of the sun wheel in the planetary gear, it is possible to control the transmission ratio and, consequently, the angular velocity of the crankshaft in the combustion engine. The range of the ratios by application of a single planetary gear is insufficient. Hence, the system was supplemented by applying additional gears, G_1 and G_2 with the constant gear ratios equal to i_{p1} and i_{p2} . Consequently, a completely automated powertrain was obtained, as it enables the vehicle to move off and steplessly control the powertrain ratios up to the maximum speed.

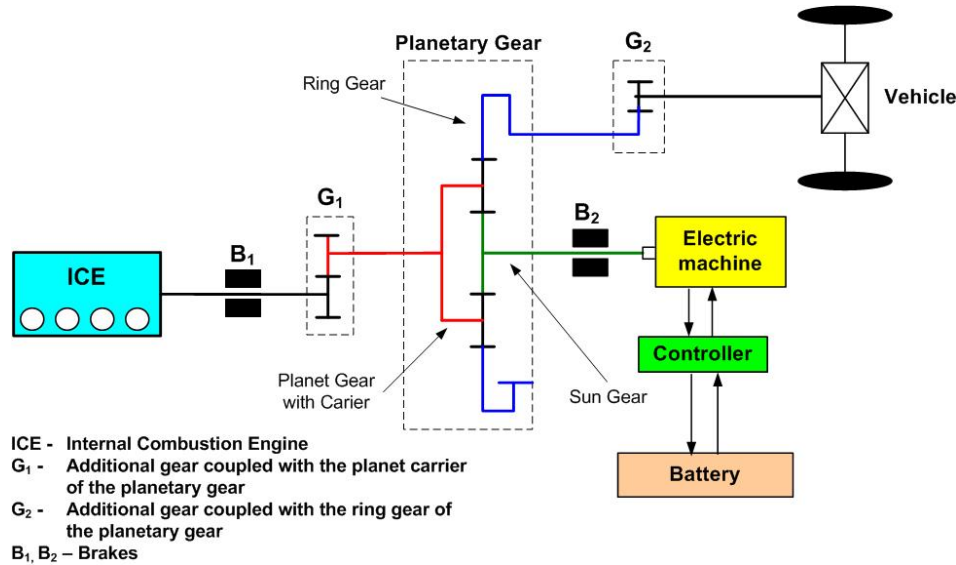

Fig. 1. Diagram of the vehicle powertrain

By accounting for the ratio of the additional gears G_1 and G_2 , the instantaneous value of the speed ratio of the planetary gear is equal to

$$R_{PG} = \frac{\omega_{ME} - (\omega_D \times i_{G1})}{(\omega_K \times i_{G2}) - (\omega_D \times i_{G1})}, \quad (1)$$

where:

i_{G1} – kinematic transmission of the G_1 gear,

i_{G2} – kinematic transmission of the G_2 gear,

ω_{ME} – angular velocity of the electrical machine,

ω_D – angular velocity of the combustion engine,

ω_K – angular velocity of vehicle wheels.

As we can see from the formula above, as a result of adopting an assumption regarding the angular velocity of the electrical machine ω_{ME} , we are able to control the speed ratio of the planetary gear, and consequently, the transmission ratio. The combustion engine plays the role of the principal power source in the considered powertrain. The power output from the combustion engine, which is transmitted to the carrier of the planetary gear, is divided in two parts. One part is transmitted on the mechanical way directly to the ring gear (i.e. to vehicle wheels). The other portion of this power is transmitted through the sun wheel coupled with the electrical machine, which works as a generator or motor depending on the vehicle speed. Within the range of the generator mode, the electrical machine receives a portion of the power of the combustion engine and transforms it into the energy to be stored in the batteries. However, during the motor mode, the electrical machine assists the combustion engine with the power output resulting from the strategy

of the power management in a manner to ensure a balance of the planetary system. The principal role of the electrical machine is associated with adjusting the angular velocity and power output of the combustion engine to the demand of the powertrain with regard to the angular velocity and torque. As a result, the principal power source – i.e. the combustion engine – is activated within the best range of its operating conditions, which results in the reduction of fuel consumption and lower emission of hazardous substances. This system also offers the advantage associated with the use of a single source, which offers the benefit of using the system with highest efficiency. For the purpose of harnessing one power source, the system has two brakes B_1 and B_2 , which can be applied to stop the carrier or the sun wheel in the planetary gear (i.e. either the combustion engine or the electrical machine), respectively. As one of the wheels is blocked, the planetary gear operates as a single-stage transmission with a constant gear ratio. Hence, the maximization of the efficiency of the powertrain and the potential increase of the control needs to involve the analysis of the control modes of the power sources. For this purpose, an integrated system was developed with the purpose of monitoring and controlling the powertrain accounting for power flow between the power sources in various control modes. The supervisory controller in this system assumes the task of coordinating the operation of the powertrain, while particular sub controllers perform functions specific to them. The proposed vehicle control system includes three controllers. An electronic controller was designed to control the operation of combustion engine by means of adjusting the position of an electronic throttle. The speed of the electrical machine is controlled by regulating the supply voltage U . In addition, it can operate in the generator mode for energy recovery. It also takes the role of controlling the input current and temperature of the motor not permitting it to overload. In case the admissible parameters are exceeded, the controller limits the power output from the electric machine. The task of the monitoring of battery parameters is performed by the BMS control (Battery Management System), which records the voltage and temperature in each of the cell, thus controlling the state of charge as well as charge and discharge currents. This prevents the system from overloading or being over discharge. Fig. 2 presents the equipment and an overview of the control system.

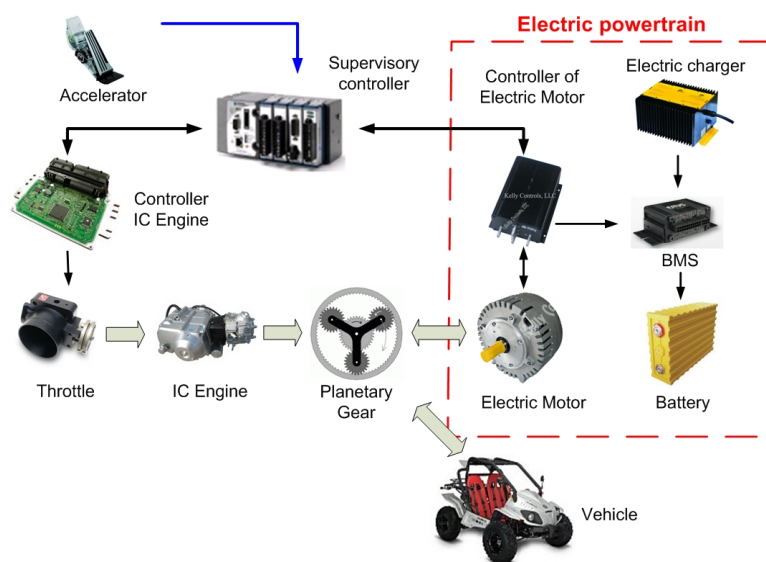

Fig. 2. Diagram of integrated powertrain control system in a buggy vehicle [6]

On the basis of the recorded sensor signals and original algorithms, the supervisory controller manages the energy flow between the combustion engine, electrical machine and the batteries. The control algorithm involves two independent control procedures: one for the throttle position, and the other for rotational speed of the electrical machine, which in turn determines the speed ratio of the planetary gear. During a single driving cycle, there are a few different phases (acceleration,

drive at a steady speed, braking); hence, the control algorithm should monitor the state of all equipment and be able to adapt to the conditions on the road. One of the principal problems is associated with the control of the electrical machine and regulation of the power flow to batteries. The electrical machine acts as a motor or generator depending on the vehicle speed. During the motor mode, it supplies energy through the converter systems. However, during the generator mode this task becomes more difficult since the energy delivered to the batteries needs to fulfil specific requirements regarding hazard of overcharging and generating excessive heat. The description of the characteristics of the operating point of the combustion engine requires the analysis of the engine performance. The identification of a criterion-based parameter makes it possible clearly to indicate the most effective operating point, on condition that a given demand for the engine power is specified. The criterion based on maximum efficiency, further called the economic curve (or E), was determined on the basis of the operating parameters of the engine corresponding to its highest efficiency for a given power demand. The insights from [3, 7] suggest that curve corresponding to the highest efficiency of the combustion engine in its initial section is situated vertically along the line of the minimum angular velocity of the combustion engine (on condition that the demand for power is low). Subsequently, following the higher power demand, the E curve turns and lies along the field corresponding to high torque produced by the engine. The small inclination of the E curve measured in relation to the x-axis means that the increase in the engine output is primarily due to an increase of its rotational speed but to a lesser degree results from the increase in its torque. Under the assumption of an input value of effective power, the total efficiency of the engine gained along the E curve is considerably higher from the one that is obtained by following the D curve (Fig. 3). The difference in the value of the overall efficiency is most clearly visible within the range of small power output. The analysed differences in the overall engine efficiencies for the E and D curves reflect the actual contradiction of the control strategies that are being followed in powertrains nowadays.

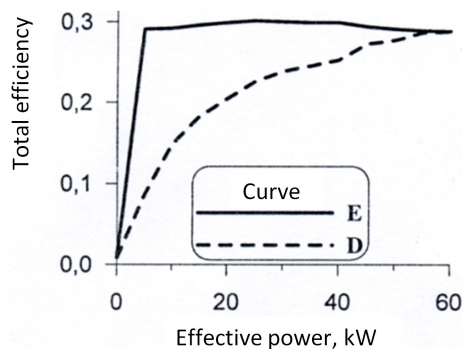

Fig. 3. Comparison of efficiency for the E and D control curves [3]

In this article, we focus on the development of the E curve for the investigated engine that is derived on the basis of external characteristics. The minimum angular velocity, which is sufficient for the vehicle to move, was estimated at 300 rad/s. For an increase in the power demand, the E curve turns towards the value of the maximum power output of the combustion engine. The criterion based on the maximum power output designed with the purpose of gaining the best performance characteristics was called the dynamic curve (or D curve). To gain the maximum acceleration, it is necessary to increase the effective power of the combustion engine. Such a gain in the effective power can be achieved by both increasing the torque as well as by increasing the rotational speed. However, the greater effective power gained as a consequence of increasing the angular velocity of the crankshaft requires that the moment of mechanical inertia needs to be overcome. Hence, the best way of increasing the power output can be associated with the greatest potential surplus of the torque produced by the combustion engine. As a consequence, the surplus of the torque can be considered to be the criterion for the identification of the course of a dynamic

curve. The D curve was developed on the basis of external characteristics of the examined engine. The end point of this curve was conducted to meet the angular velocity corresponding to the maximum power output. The control curves developed in this way (Fig. 4) were applied with the purpose of identifying the basic coordinates for the control of the combustion engine defining the most effective range of engine operation (E curve) and an operating range with the most effective motion characteristics (D curve). These curves E and D are described by the formulas:

$$\omega_E = 4 \cdot \Theta + 300, \quad (2)$$

$$\omega_D = 2 \cdot \Theta + 500, \quad (3)$$

where: ω_D – angular velocity of the engine, rad/s, Θ – throttle position, %.

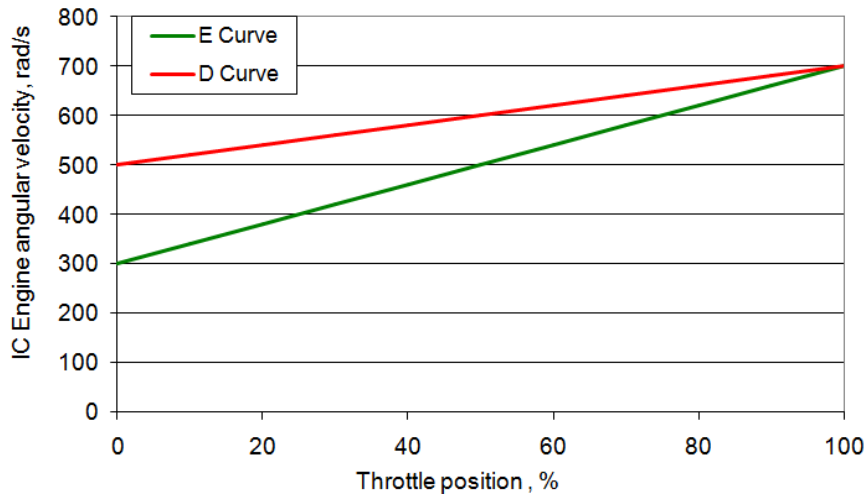

Fig. 4. Characteristics of the operating range of combustion engine

On the basis of the demand for the angular velocity of the combustion engine ω_D (derived on the basis of the throttle position Θ) and the angular velocity of the crankshaft ω_{WN} driving vehicle wheels, we can calculate the required transmission ratio i_{UN} . It is defined by the following relation:

$$i_{UN} = \frac{\omega_{WN}}{\omega_D}. \quad (4)$$

Hence, for the purpose of defining the given rotational speed of the electrical machine, which determines the transmission ratio, we need to take into account the angular velocities of the engine and crankshaft while accounting for all kinematic relations in the examined powertrain, including the planetary gear. A function was developed with the aim of determining the demand of the electrical machine with regard to the required velocity. A control module developed by these authors is applied to determine the velocity of the electrical machine ω_{ME} and it forms one of the key parts in the new powertrain design. The input signals for this module include: velocity demand of the engine crankshaft ω_D and the instantaneous crankshaft speed ω_{WN} . The speed of the electrical machine derived in the above manner can be later transferred to the controller of the electrical machine, which applies a PID regulator to control the instantaneous speed and torque of the electrical machine. As a consequence, we can control the engine speed within the range of the values demanded by the powertrain. However, this type of control reduces the applicability of the electrical machine only for the purpose of continuous power transfer from the engine to the vehicle wheels. Hence, it is not possible to assist the powertrain by power transfer from the electrical machine to the vehicle wheels during acceleration. This is due to the fact that this could lead to the distortion in the power flow from the engine to wheels and, consequently, a change in its angular velocity.

3. Simulation model

The simulations were performed in the MATLAB/Simulink environment. The development of a model applies original models selected from the library of the MATLAB/Simulink software. The model of the vehicle coupled with the powertrain including a planetary gear is presented in Fig. 5. In the hybrid mode, the UDC (Urban Driving Cycle) was applied for various angular velocities of the engine (200, 300, 700 and 900 rad/s) following the control curves E and D described earlier. The prerequisite for the control followed in the simulations was associated with preserving a constant speed of the engine at around 300 rad/s during the driving cycle and 0 rad/s at a standstill. The control of the vehicle speed was performed as a result of controlling the throttle opening in the engine. At the same time, the motor is responsible for the control of the speed ratio of planetary gear. The course of the angular velocity of the electrical machine indicates how this machine adapts its angular velocity in such a manner that the engine operates under a given angular velocity. The results of the simulation of the UDC cycle indicate that the engine can be maintained at a constant operating point over the entire range of the vehicle speed. By controlling the ratio of the planetary gear, the electrical machine regulates the speed ratio and, simultaneously, keeps the angular velocity of the engine crankshaft at a specified level (200, 300, 700 and 900 rad/s). The analysis of the vehicle parameter in the transient states of the engine, i.e. during the varying angular velocity of the crankshaft, was performed for the UDC cycle on the basis of the earlier defined control curves (E and D). The functions of the control curve E and D define the input with angular velocity of the engine on the basis of the throttle position. The analysis of the course of the angular velocity of the engine visible in Fig. 6 indicates that the control of the operating point of the engine is possible during all phases during this cycle. Depending on the throttle position, the control algorithm determines the demanded speed of the combustion engine, which is subsequently maintained by the electrical machine.

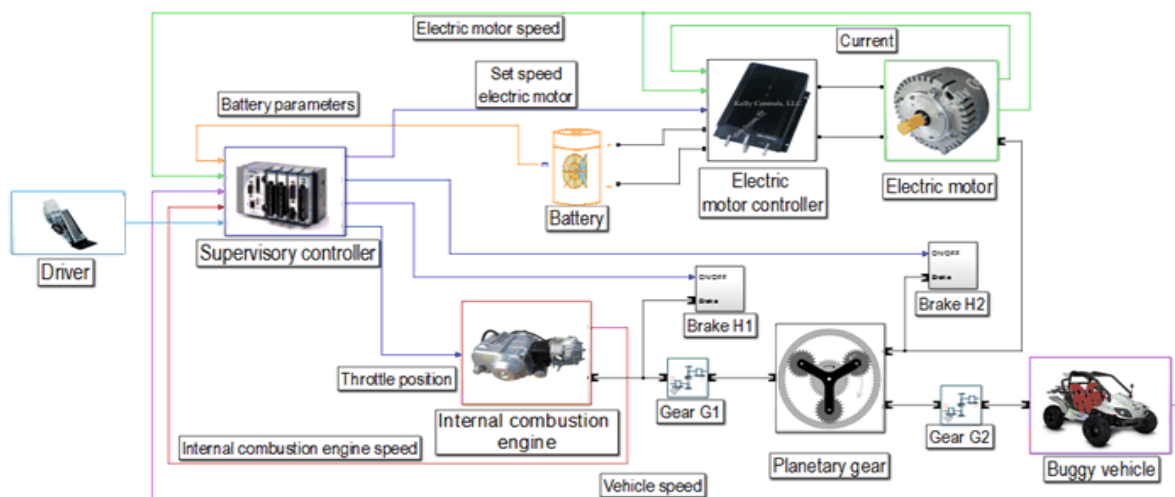

Fig. 5. Simulation model of the powertrain with electrically controlled planetary gear

In the hybrid mode, the smallest fuel consumption was gained for the given angular velocity of the combustion engine equal to 200 rad/s. Concurrently, the smallest equivalent fuel consumption was gained in the electric mode, where electricity was applied as the single source of power. The highest value of fuel consumption was gained for the angular velocity of the combustion engine equal to 900 rad/s. The mean values of fuel consumption correspond to the control performed according to the E and D curves between the engine speeds between 300 rad/s and 700 rad/s. This is quite clear since the values gained on the basis of the curves were situated in this range. However, the control performed according to the E curve offers lower consumption from the one in which the dynamic curve (D) is followed.

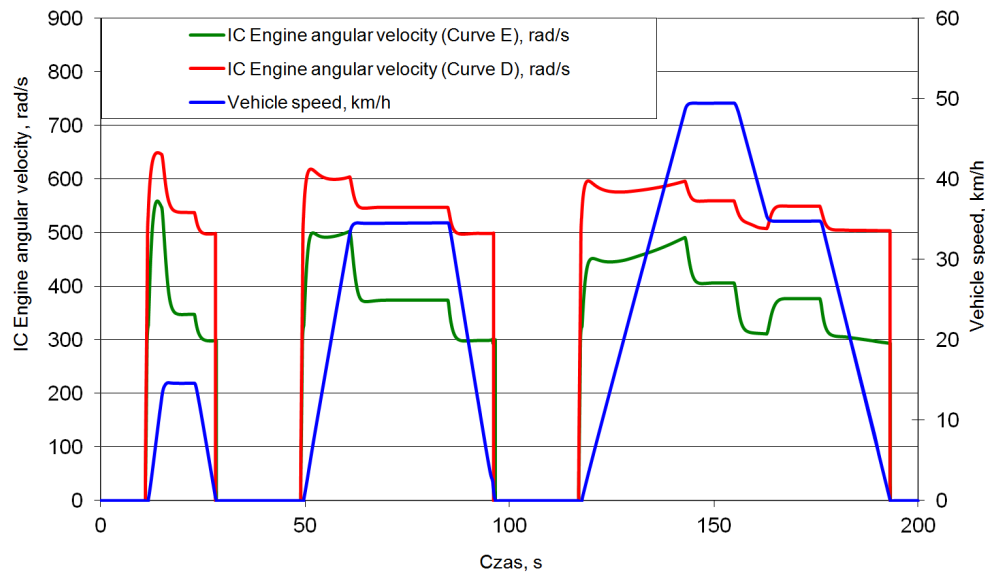

Fig. 6. Characteristic of variability of angular velocity of the engine in time using E and D control curves during UDC cycle

4. Summary of study results

A detailed analysis of the component of a powertrain was performed on the basis of simulations of a system with an electric planetary gear. The simulations indicate that the application of an electrically controlled planetary gear can be successfully applied for the control of the transmission ratio. The solution to the problem of the control in the examined powertrain needs to account for the characteristics of the components of such a system, including the engine, motor and batteries. Hence, an analysis of the control algorithms was conducted on the basis of the adequately developed driving cycles. The best efficiency of the engine and lowest fuel consumption was registered for the UDC cycle for a constant engine speed equal to 200 rad/s. In these conditions, the engine operates within the range of low rotational speeds of the crankshaft, i.e. works with the highest efficiency. In turn, the lowest fuel consumption was gained for the control of the angular velocity of the engine according to the E curve, which confirms the correct assumptions adopted during its development. In addition, strategies involving the use of energy extracted from the electrical machine working as a generator, which applies a part of the power output of the combustion engine or energy regained of the braking vehicle. The energy for battery charging could also be taken from the electrical grid. The energy derived during braking does not lead to fuel consumption; however, the energy produced by the electrical generator driven by the engine affects its total fuel consumption. In the proposed powertrain applying the electrical machine for the control of the angular velocity of the engine, the range of the motor and generator operation depends on the vehicle speed and set value of the engine's angular velocity. For this reason, the control of the engine is performed by the electrical machine (by operating in the motor and generator mode).

The efficiency of the battery charging in the hybrid mode is mostly relative to the operating point of the engine. The optimization of the process of power generation by the electrical machine requires that the operating point of the engine be maintained at a range at which its high performance is guaranteed. The power derived in the examined powertrain can be subsequently applied in the electric mode. On the basis of the study conducted in the UDC cycle, we can conclude that the best traction characteristics, lowest fuel consumption and lowest emission were registered during the electric cycle coupled with the hybrid one. In the electric-hybrid mode, the most important task involves the utilization of the electric drive to the greatest possible extent. If the demand with regard to the speed exceeds the maximum speed for the electric mode, the

powertrain switches to the hybrid mode. In this mode, the principal task of the control is to recharge the batteries by using power from the combustion engine so that the electricity utilized in the electric mode is recharged as quickly as possible. The power deficiency resulting from the operation of the vehicle in the electric mode is solved by the application of an adequate control algorithm, which accounts for the battery state of charge, and the utilization of the electric and hybrid mode will follow from there.

References

- [1] Bashash, S., Moura, S. J., Forman, J. C., Fathy, H. K., *Plug-in hybrid electric vehicle charge pattern optimization for energy cost and battery longevity*, Journal of Power Sources, Vol. 196, pp. 541-549, Elsevier 2011.
- [2] Chau, K. T., Wong, Y. S., *Overview of power management in hybrid electric vehicles*, Energy Conversion and Management, Vol. 43, pp. 1953-1968, Elsevier 2002.
- [3] Jantos, J., *Zintegrowane sterowanie samochodowym, spalinowym układem napędowym o przełożeniu zmiennym w sposób ciągły*, Oficyna Wydawnicza Politechnika Opolska, Opole 2003.
- [4] Kim, J., Kang, J., Kim, Y., Kim, T., Min, B., Kim, H., *Design of Power Split Transmission: Design of Dual Mode Power Split Transmission*, International Journal of Automotive Technology, Vol. 11, No. 4, pp.565-571, KSAE 2010.
- [5] Lechowicz, A., Augustynowicz, A., *Modeling and Simulation of the Hybrid Powertrain for the Use in Urban Vehicle*, Mechatronics – Ideas for Industrial Application, 2015, Vol. 317, pp. 473-482.
- [6] Lechowicz, A., Augustynowicz, A., *Modeling and Simulation of the Hybrid Powertrain for the Use in Buggy Vehicle*, International Symposium on Electrodynamic and Mechatronic Systems (SELM 2013), pp. 43-44.
- [7] Mitschke, M., *Dynamik der Kraftfahrzeuge. Band C: Fahrverhalte*, Springer Verlag, 1990
- [8] Joint publication, *Hybrid Drives, Fuel Cells and Alternative Fuels*, Technical Instruction Booklet, Robert Bosch GmbH 2008.
- [9] Szumanowski, A., *Hybrid Electric, Vehicle Driver Design*, ITEE, Warszawa – Radom 2006.