

STUDIES ON THE SUPPORTING STRUCTURE OF THE "CROSSBOW" ROCKET LAUNCHER IN THE ASPECT OF IMPROVEMENT OF ITS RESISTANCE PROPERTIES

Piotr Rybak, Waclaw Borkowski, Zdzisław Hryciów
Bogusław Michałowski, Andrzej Wiśniewski, Józef Wysocki

*Military University of Technology
Institute of Motor Vehicles and Transportation
Kaliskiego Street 2, 00-908 Warsaw, Poland
tel.: +48 22 6897752, fax: +48 22 6837370
e-mail: prybak@wat.edu.pl*

Abstract

This paper presents the results of the studies on a special vehicle Polaris Ranger 6×6 800 equipped with the "Crossbow" anti-aircraft rocket launcher, manufactured by TELESYSTEM-MESKO Sp z o. o. Implementation and Manufacture Centre. The supporting structure of the launcher made the main object of the analysis. The essential goal of that undertaking was to obtain a structure of resistance assuring reliable system operation in various conditions of use. In order to reach that goal, the experimental as well as the model tests have been performed on the launcher vehicle. The experimental tests were carried out during multi-variant rides on the paved roads and in the wilderness of significant level of unevenness. Significant information on the level, directions and nature of affecting dynamic loads and the effects of their influence on the vehicle elements. The analysis of obtained results also provided the data required for a development of a model of the object of the studies. A MES model of the object of the studies was prepared in the LS-DYNA system. A high pressure was put on modelling a complex chassis of the launcher and mutual reaction of assemblies and parts. A generalized issue on the own properties was solved – frequencies and associated forms of vibrations of own main assemblies were designated. Resistance calculations were carried out for assumed loads. In principle, loads imposed by normative requirements for a particular class of armament and military equipment were assumed. Loads resulting from potential conditions of use and installation on other carriers were also included. The tests were performed for various load variants. Sensitive elements of the chassis were modified and highly satisfying results were obtained. It gives a reason to think that the chassis is resistant to expected and difficult operation conditions and assures that the whole system will work reliably.

Keywords: *structure, dynamical loads, experimental research, numerical research*

1. Introduction

In many cases the use of capabilities of the advanced technology depends on the supplementing systems. However, that type of combined solutions cannot include weak links. Therefore, there is a need to fulfil undertakings that provide the same or similar level of operation.

This paper presents the methodology of shaping the supporting structure of the "Crossbow" anti-aircraft rocket launcher installed on the chassis of Polaris Ranger 6×6 800. Multi-variant and multi-aspect experimental and launcher model tests were carried out in the process of shaping the supporting structure.

2. Experimental launcher tests

The anti-aircraft rocket launcher in the aforementioned vehicle made the subject of the tests. The general view is presented in Fig. 1. The launcher in that version is installed on a prototype base making its supporting structure.

The experimental tests were carried out in two stages during rides at set and recorded speeds of motion. The first stage was performed on a paved road during rides over obstacles of a known

shape, arranged symmetrically or non-symmetrically – Fig. 2. Some of obtained results are presented in Fig. 3, while Fig. 3a presents courses of forces in the supporting nodes between the frame and transport box, while Fig. 3b presents courses of vertical, longitudinal and transverse accelerations under the column of the supporting structure of the launcher. The second stage – the experimental tests at random loads were carried out in the military training area of the Military Technical University during rides on the gravel road and pathless areas of significant folding level, including various weather conditions – Fig. 4. Selected test results are presented in Fig. 5, while Fig. 5a presents time courses in the supporting nodes of the transport box, while Fig. 5b presents time courses of vertical, longitudinal and transverse accelerations under the launcher column.



Fig. 1. General view of the basic version of the “Crossbow” launcher



Fig. 2. The vehicle during rides over the obstacles of a known shape

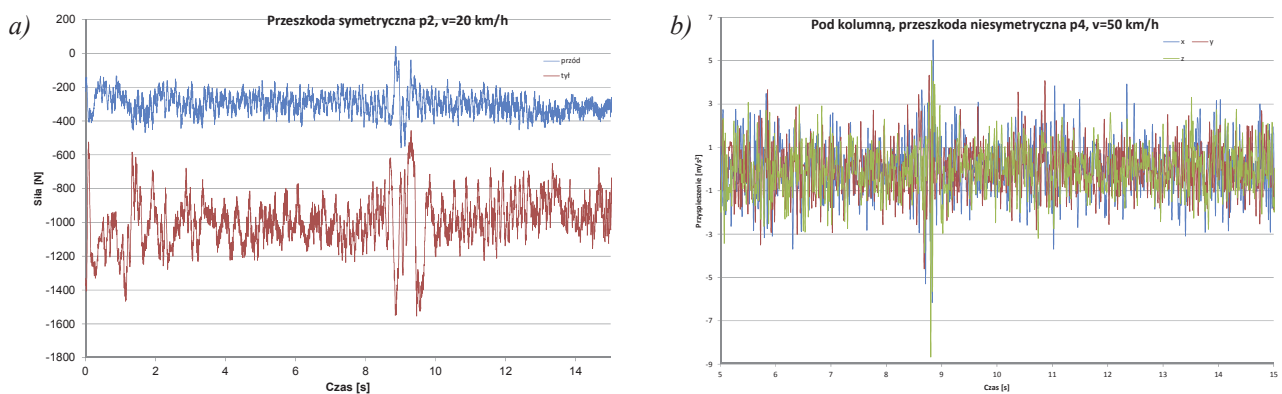

Fig. 3. Time courses of recorded parameters: a) forces in the structure supports, b) accelerations under the launcher column



Fig. 4. Tests in the military training area conditions

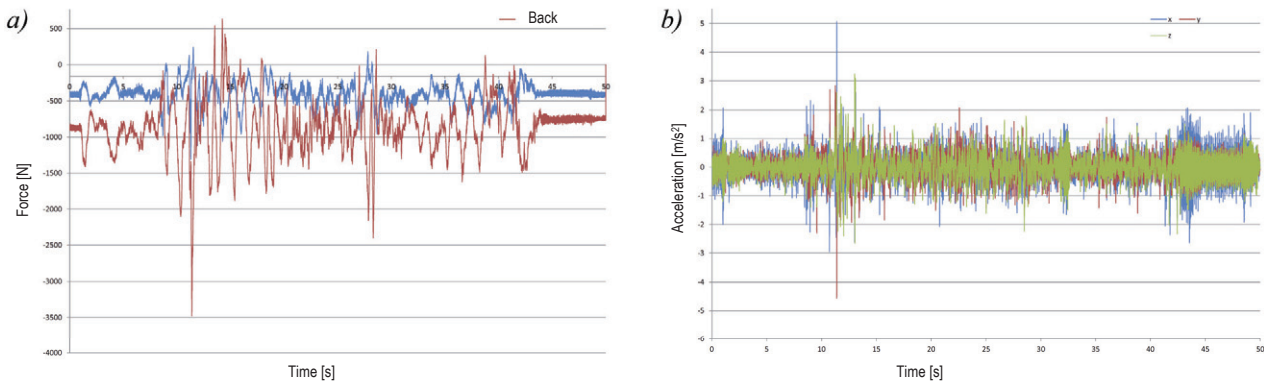

Fig. 5. Time courses of recorded parameters: a) forces in the structure supports, b) accelerations under the launcher column

The analysis and evaluation of obtained results indicated a need for modification of the supporting structure and provided significant information that was used to develop a MES model of the unit in the LS-DYNA system. Valuable information concerning the level of loads generated during the use of that type of vehicles was also obtained.

3. Model tests

The test object model was partially based on a prototype structure, however the fundamental part of the supporting structure was modified both in respect of the geometry and the materials.

Model tests of the modified supporting structure of the container were performed at two stages. During the first stage, own vibrations were considered and the model structure properness was verified. At the second stage, own vibration tests were carried out for assumed load variants in accordance with requirements for that class of equipment.

3.1. Own vibrations

A generalized issue of own values has been solved for a developed model. A special attention was paid to the supporting structure of the launcher and some sensitive elements when developing that model. Basic frequencies of own vibrations and associated forms vibrations were calculated. The frequencies are specified in Tab. 1, while the first and the third form of vibrations are presented in Fig. 6.

Tab. 1. Frequencies and forms of own vibrations in the model of the supporting structure of the launcher

Frequency No.	Vibration frequency f (Hz)	Vibration period T (s)	Vibration form
1.	1.30	0.77	Longitudinal angle vibrations (against axis x)
2.	2.34	0.43	Transverse angle vibrations (against axis z)
3.	2.52	0.40	Vertical vibrations
4.	2.69	0.37	Transverse angle vibrations (against axis z)
5.	5.86	0.17	Longitudinal angle vibrations of the rocket platform
6.	6.95	0.14	Transverse angle vibrations of the rocket platform unit

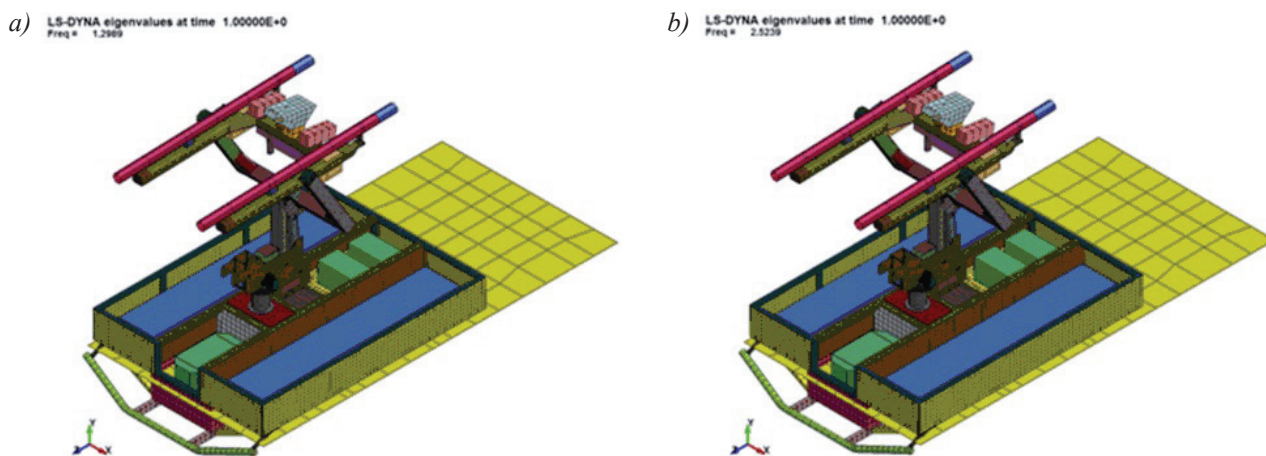

Fig. 6. Selected forms of own vibrations of the supporting structure of the container: a) the first form for the frequency $f_1 = 1.3$ Hz, b) the third form for the frequency $f_2 = 2.52$ Hz

The fact that the basic vibration frequencies do not match the frequencies of the own vibrations of the transporting trailer and frequencies characteristic for the ground makes a significant advantage of the modified supporting structure.

3.2. Forced vibrations

Forced vibration tests were performed in the aspect of evaluation of the effort condition of the supporting structure of the launcher. The objective was to identify and eliminate possible sensitive elements from the structure and make possible modification in order to obtain high resistance to loads, even exceeding the limits. Calculations were made for assumed load variants, resulting from expected the most adverse cases that might occur during operation. The load required by the official

standards was assumed as the essential load of the analysed model of the supporting structure of the launcher. They impose the influence of multiple mechanical impacts and single impacts of set amplitudes of acceleration and duration for that type of equipment. Fig. 7 and 8 present selected calculation results proper for one of the variants.

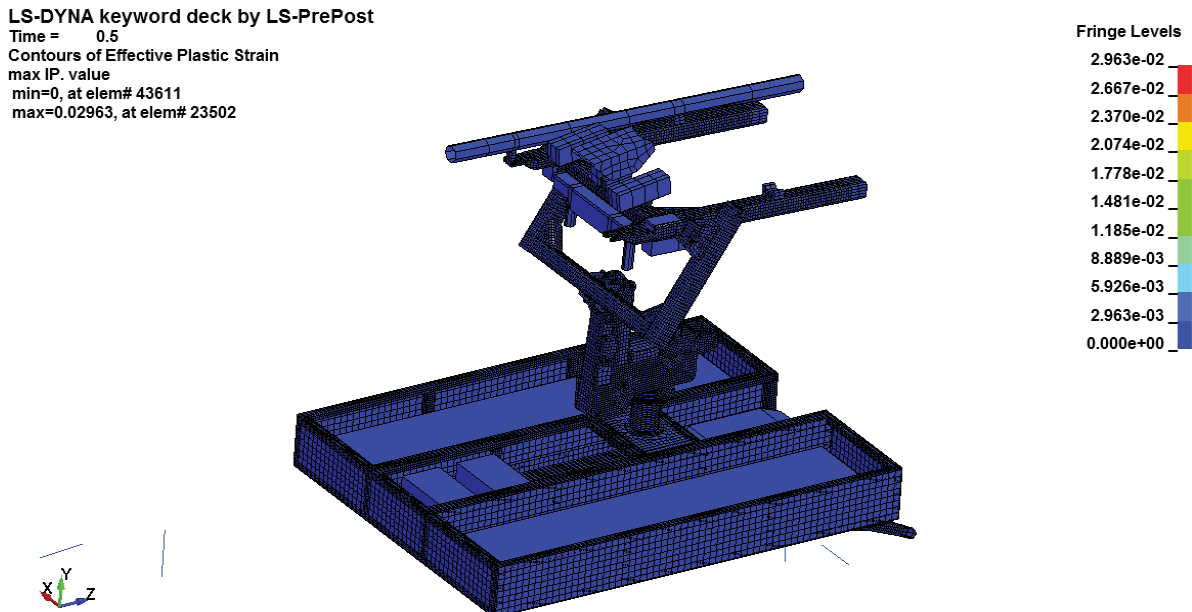

Fig. 7. Deformations of the supporting structures for assumed load variant

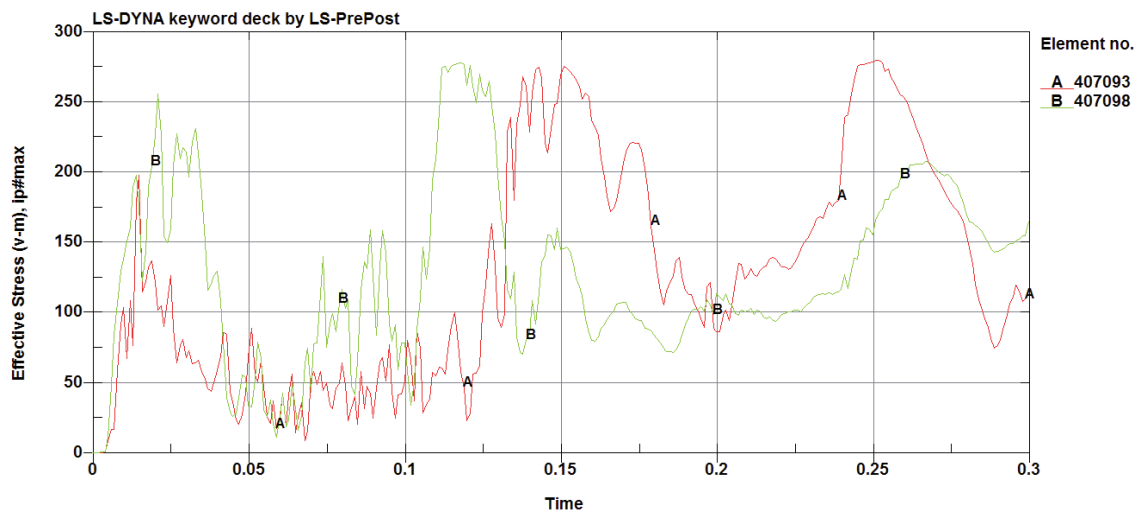

Fig. 8. Reduced stress [MPa] in the platform unit

Results obtained from numerical tests, their reference to the experimental test results allowed for a careful evaluation of individual elements of the supporting structure of the launcher.

4. Summary

The resistance analysis of the supporting structure of the launcher has been carried out with assumption that ready-to-use equipment installed on the supporting structure has to meet the requirements of the defence standards or other regulations concerning the mechanical risks.

As a result of multi-variant experimental tests and model tests as well as rational modification, a functional supporting structure was obtained. It assures high resistance and in effect it provides reliability of efficient execution of tasks.

References

- [1] Mitschke, M., *Dynamika samochodu*, WKiŁ, Warszawa 1977.
- [2] Borkowski, W., Rybak, P., Hryciów, Z., Michałowski, B., *Wpływ stanu technicznego zawieszenia na obciążenia dynamiczne pojazdu specjalnego*, Teza Komisji Motoryzacji PAN o/Kraków, Zeszyt nr 33–34, str. 37–44, 2008.
- [3] Borkowski, W., Rybak, P., Michałowski, B., Pańczuk, E., *Model Investigations of Traction Properties of the High-Speed Tracklaying Vehicle*, Journal of KONES Powertrain and Transport, Vol. 15, No. 2, pp. 409–414, 2008.
- [4] Borkowski, W., Michałowski, B., Rybak, P., Wiśniewski, A., *Numerical Research on Dynamic Loads of Wheeled Armoured Personnel Carrier During Overcoming Terrain Obstacles*, Journal of KONES Powertrain and Transport, Vol. 19, No. 4, pp. 37–44, 2012.