

MODEL BASED PREDICTION OF THE CRANKSHAFT INSTANTANEOUS ANGULAR SPEED FLUCTUATIONS

Mirosław Dereszewski, Adam Charchalis

Gdynia Maritime University, Mechanical Faculty
Morska Street 83, 81-225 Gdynia, Poland
tel.: +48 58 6901398
e-mail: deresz1@o2.pl, achar@am.gdynia.pl

Abstract

The paper presents results of the calculation, based on simplified engine model, aimed on prediction of IAS (Instantaneous Angular Speed) of the crankshaft fluctuations under faulty engine condition. Gas forces were calculated basing on results of in-cylinder pressure measurements which were used as inputs to the dynamic model. Mass forces were calculated basing on technical particulars of the engine Sulzer 3AL 25/30. Measurements of the in-cylinder pressure was carried out at laboratory stand in Gdynia Maritime University, equipped with diesel engine Sulzer 3AL 25/30 driving electro-generator. Sulzer 3AL 25/30 is three cylinder, medium speed, four stroke marine diesel engine, with maximum output 408 kW at 750 rpm. In order to evaluate of IAS model utility for diagnostic prediction of the engine behavior, two kinds of malfunctions of engine's fuel system were simulated. First malfunction was fuel leakage from high pressure line; the second was partly plugged injector's nozzle. Construction of high pressure fuel pump enable to fuel leakage simulation. The engine was run out at load 250 kW what is around 65% of nominal. Results of all measurement were smoothed in order to eliminate a noise using SG (Savitzky – Golay) filter. Results of fault condition modeling were compared with healthy engine model and with results of in -cylinder pressure diagrams, in order to create a map of deviations from normal condition.

Keywords: diagnostics, marine diesel engine, angular speed modeling, failure symptoms

1. Introduction

Marine Diesel Engines are widely used on board of vessels as main propulsion and auxiliary engines, e.g. diesel generators. Due to importance of such mechanisms for ships operation and safety, and obvious fact that reparation on board is complicated by rough sea state and limited spare parts supply, to ensure reliability of these engines is primary importance. Engine's condition monitoring helps predict and avoid failures of equipment.

Many malfunctions of diesel engines are related to the combustion process. The process can be disturbed because of wrong functioning of subsystem such as valves and a camshaft, an injection system (high pressure pumps and injectors), a turbocharger, or piston and cylinder liner wear. The in-cylinder pressure contains many data about the combustion process. However, direct measurement of in-cylinder gas pressure is impractical and quite expensive [1]. For every cylinder installation of a transducer is necessary, but these tend to have limited lifetime due to exposure at high temperature and pollutants.

Analysis of the crankshaft Instantaneous Angular Speed (IAS) variation has been in focus of attention for several years [2]. Convenience of that method is non-invasive measurement and relatively easy mounting of measurement system elements [3]. According to some authors, analysis of the lowest harmonics can even point the faulty cylinder [5]; other methods are focused on indicated torque.

This work is dedicated to validation of IAS calculation basing on the engine dynamic model. In order to enhance the model correlation to real condition, values of cylinder pressure measured during experiment, were taken as input. As an object of modelling and experiment was selected three cylinders, four stroke diesel engine driving an electro generator.

As the method of evaluation of the IAS model utility for fault detection, has been undertaken comparison of records done under different, but typical malfunctions of fuel system, with the healthy engine, and subsequent approach to identification of source of troubles. Simulated malfunctions were leakage from injection pump and partly plugged injector nozzle. The value of leak was adjusted proportionally to of on-line measured pressure of fuel in the injector pipe.

2. The characteristics of the engine and test rig

The experiment was fully carried out at the test bed in Mechanical Faculty Engine Laboratory. Short description of the engine and test equipment is presented below.

2.1. Description of the engine

AI 25/30 is a turbocharged medium speed diesel engine designed by Sulzer. This 3 cylinder in line engine develops 408 kW, at rotational speed of 750 rpm. The engine drives alternate current electro generator GD8-500-50, 500kVA, connected to the main electric board. The load of the engine can be fluently adjusted by changing of the load of generator (adjustable resistor). The high pressure fuel system has three injection pumps, one for each cylinder. General view of the high fuel set of one cylinder is presented in Fig. 1.

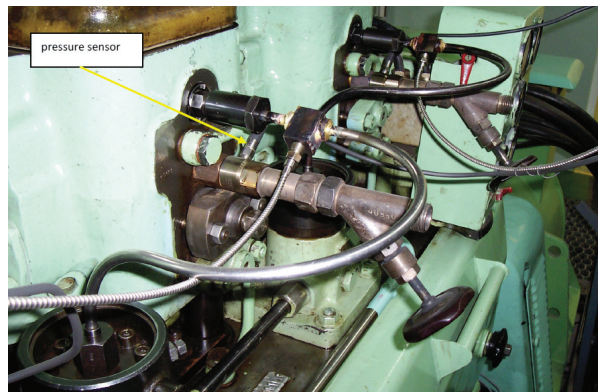

Fig. 1. Pressure sensor Kistler installed in indicator cock

In-cylinder pressure measurement was carried out using Diesel Engine Tester UNITEST 2008. This system is the permanent equipment of the laboratory test bed and enables measurement of in-cylinder pressure and high pressure fuel pipe pressure in every cylinder in the same time. The system consists of three pressure sensors enabling simultaneous measurement in every cylinder. Results in form of pressure diagram in domain of crankshaft angle are displayed at computer screen (Fig. 2).

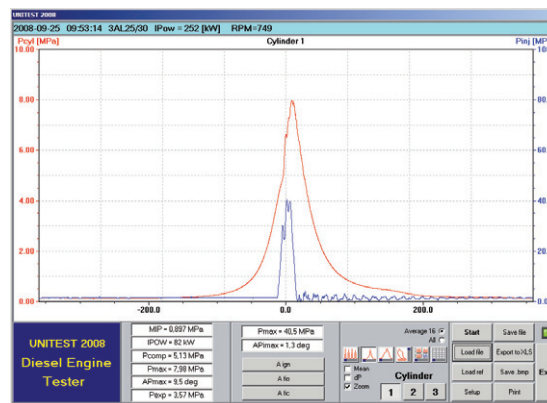

Fig. 2. Window of Diesel Engine Tester with diagrams of in-cylinder and high pressure in fuel tube

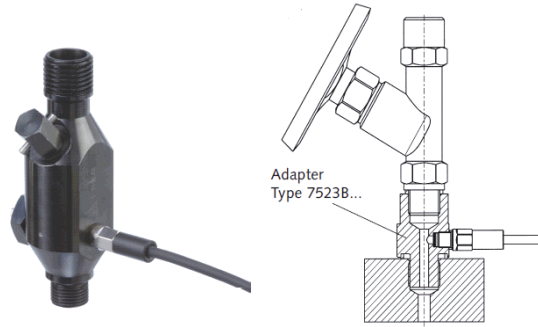

Fig. 3. In-cylinder pressure sensor Kistler type with special adapter

3. Results of measurements

The aim of measurements was to collect pressure data of every cylinder when engine runs out under healthy and faulty conditions. Values of in cylinder pressure were necessary for calculating of gas pressure creating gas tangential forces. Measurements were conducted at load of 250 kW. Implemented faults simulations were leak from the high pressure pump at 2nd cylinder and partly clogged injector nozzle at 2nd cylinder.

The measurements of healthy engine pressure at different loads were done in order to get a template picture, for further comparison with records done in malfunction conditions. First malfunction was the leakage from injection pump number 2. The level of leakage was adjusted basing on observation of high pressure fuel decreasing, at UNITEST display, and was established at $\approx 30\%$ max. pressure down. In order to get records of impact of an injector malfunction, specially prepared injector with plugged 30% of nozzle openings was installed in 2nd cylinder's head. On charts below are presented superposed waveforms of cylinder pressure, according to firing order 1-2-3, starting in TDC of working stroke of first cylinder.

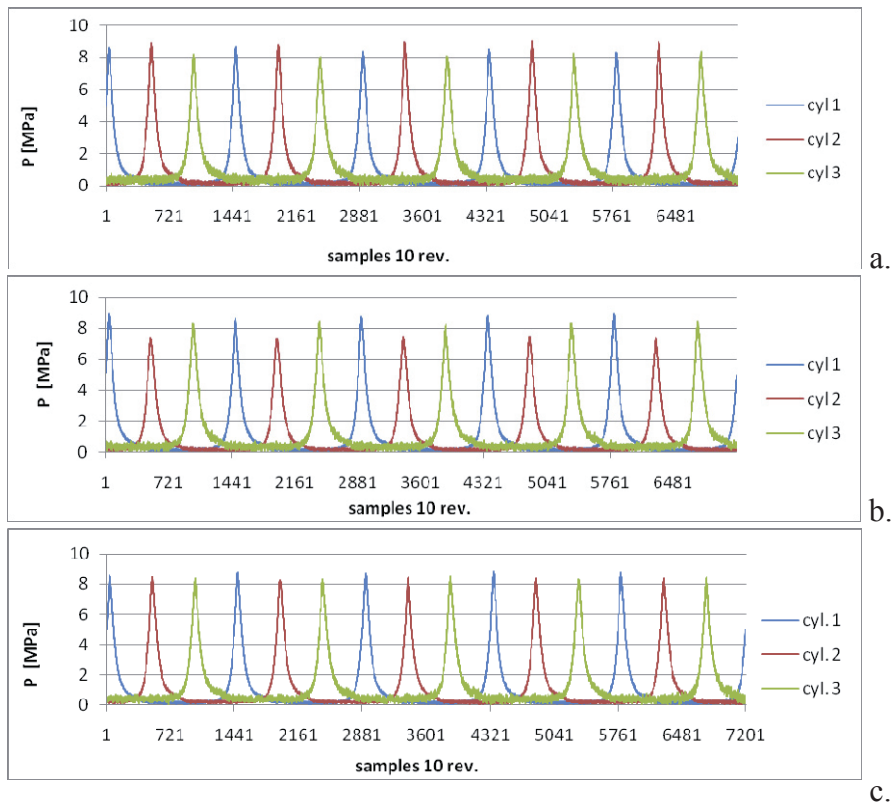

Fig. 4. Angular speed variations of healthy engine- (1), fuel leakage - (2), and clogged injector - (3). Load 250 kW, domain of samples of 10 revolutions

Observing changes of pressure one has to notice decrease of maximal peak in 2nd cylinder when fault of leakage was implemented. For clogged injector, situation is similar, but diminishing of maximal peak is not so significant (Fig. 4). More accurate analysis shows also that affected 2nd cylinder is the source of interference in 1st and 3rd cylinders.

3.3. Model of crankshaft rotary movement

Gas pressure force is straight related to indicated torque, thus its changes shall be reflected in angular speed fluctuation. Because of geometry of piston – connecting rod – crankshaft system, tangential force F is described by equation (1).

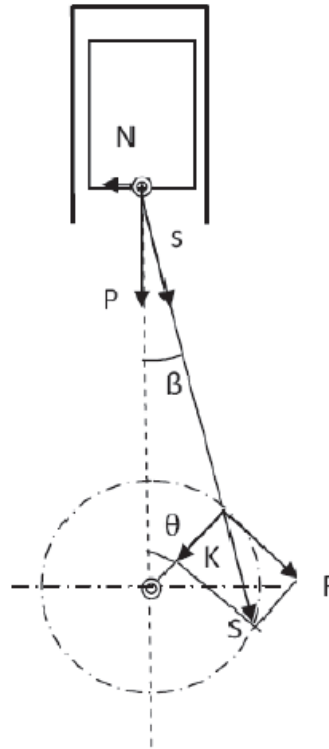

Fig. 5. Geometry of piston –connecting rod – crankshaft system

$$F = P(\sin \theta + \frac{1}{2} \lambda \sin 2\theta), \quad (1)$$

where:

P - gas force,

λ - crank to connecting rod length ratio.

For modeling purposes one has to assume that the crankshaft is sufficiently rigid, the load torque is constant and engine is decoupled from the load, thus the engine dynamics can be described by equation (2)

$$E(\varphi) \frac{d^2 \varphi}{dt^2} = T_{gas} - T_{mas} - T_{load} - T_{fr}, \quad (2)$$

where:

J_E - mass inertia on engine side

$T_{gas}, T_{mas}, T_{load}, T_{fr}$ - respectively gas, mass, load and friction torques.

The gas torque, deriving from in-cylinder pressure was calculated according to equation (3) [4]. Values of gas pressure in domain of crankshaft angle were directly measured in health condition and with fault simulation.

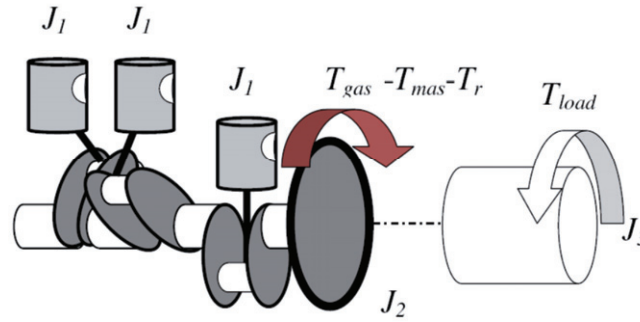

Fig. Torque balance and mass inertia in 3-cylinder engine

$$T_{gas} = P * A * 0.5s \left[\sin \theta + \frac{\lambda \sin 2\theta}{2\sqrt{1 - \lambda^2 \sin^2 \theta}} \right], \quad (3)$$

where:

P - in-cylinder pressure,

s - stroke,

A - piston area,

θ - crank angle.

Torque created by inertia forces of masses of pistons, connecting rods and cranks in reciprocating movement, for three cylinder engines can be calculated by equation (4).

$$T_{mas} = m_p r w^2 \left(-\frac{9}{4} \lambda \sin(3\theta) + \frac{9}{32} \lambda^4 \sin(6\theta) \right). \quad (4)$$

Friction torque was calculated experimentally, in way of measurement of mean effective pressure when engine was working without load.

4. Detection of malfunction presence, source and marking of affected cylinder

After analysis of healthy and disturbed waveforms of IAS, became obvious that simple comparison is not sufficient for definition of the malfunction. Better picture of disturbances is given by comparison of waveforms presenting angular speed difference between healthy and faulty condition, at the same load value [6]. Analysis of tendencies and magnitudes can give the information about malfunction presence and its character. Samples of relative angular speed differences between healthy - leakage fault and healthy - plugged injector are presented at Fig. 6 and Fig. 7.

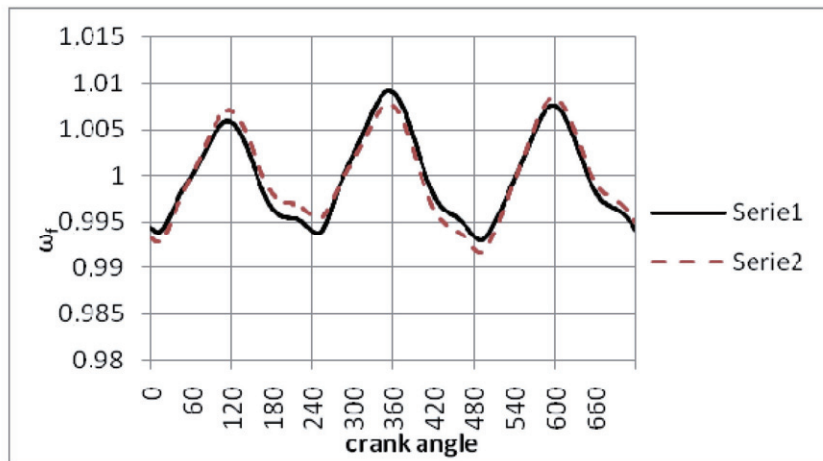

Fig. 6. Angular speed variation difference comparison: healthy engine – solid line, and malfunction of high pressure fuel pump - dotted line

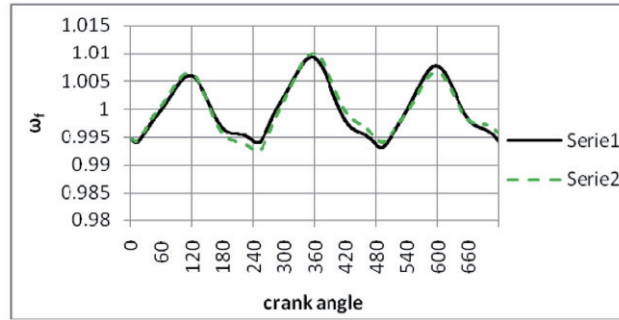

Fig. 7. Angular speed variation difference comparison: healthy engine – solid line and malfunction of injector- dotted line

Occurring of the malfunction is shown due to magnitude amplification. Detection of faulty cylinder in the case of fuel leaking can be done in the way of first derivative analysing between maximum and minimum value of variation's difference, in every interval (240°) between TDC's of the work stroke of each cylinder (Fig. 8). In the case of partly plugged injector, analysis of amplitude span is similar to fuel leak case, but strength of deviation is lower (Fig. 9).

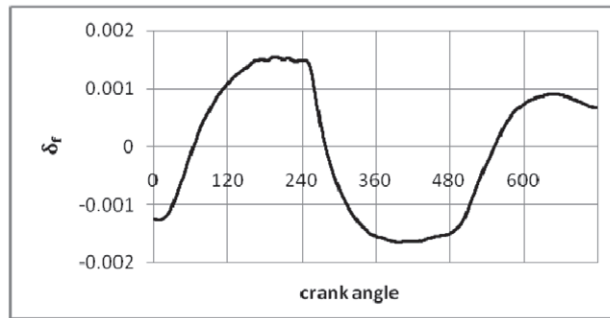

Fig. 8. Waveform of angular speed fluctuation difference between healthy engine and leakage fault

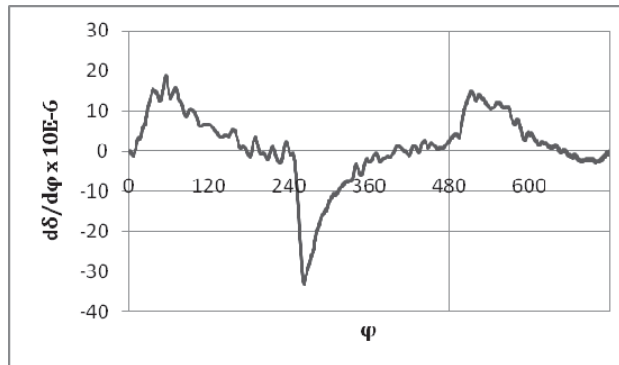

Fig. 8. Waveform of derivative of angular speed fluctuation difference between healthy engine and leakage fault

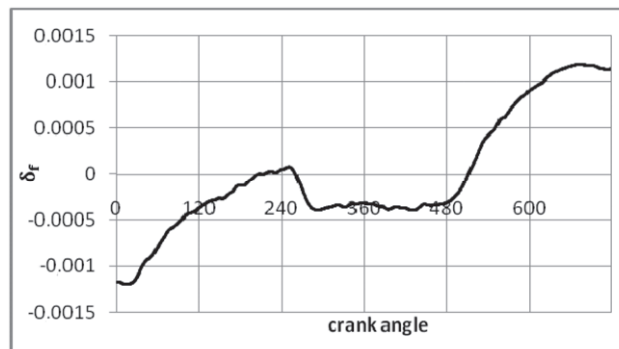

Fig. 8. Waveform of angular speed fluctuation difference between healthy engine and injector fault

5. Conclusion

The results of conducted simulation showed that malfunctions of fuel system were the source of angular speed deviations. The level of deviations forced by in – cylinder pressure changes are strong enough to be detected by model. The most effective way to receive diagnostic information is comparison of healthy and faulty condition IAS waveforms. The conclusion coming from above is that for detection and localisation of malfunction, necessary is template measurements of a healthy engine. From diagnostic practice is known that collecting of healthy engine data can be difficult, especially for engines being in permanent exploitation. To avoid that inconvenient limitation, a template in a form of healthy engine measurements can be replaced by very accurate mathematical dynamic model of a crankshaft movement.

Cylinder pressure measurement carried out during experiment, shows that one cylinder deviations affect others, and cannot be omitted. It means that fault simulation by simple decreasing of magnitude in one cylinder is not equal with real response of faulty engine. Construction of engine's dynamic behaviour model should be based on pressure values obtained in experimental way or pressure model sustaining real changes tendency.

References

- [1] Polanowski, S., *Studium metod analizy wykresów indykatorowych w aspekcie diagnostyki silników okrętowych*, Zeszyty Naukowe AMW Nr 169 A, 2007.
- [2] Desbazeille, M, Randall, R. B., Guillet, F., El Badaoui, M., Hoisnard, C., *Model-based diagnosis of large diesel engines based on angular speed variations of the crankshaft*, Mechanical Systems and Signal Processing 24, 2010.
- [3] Dereszewski, M., Charchalis, A., Polanowski, S., *Analysis of diagnostic utility of instantaneous angular speed of a sea going vessel propulsion shaft*, Journal of KONES, Vol. 18, No. 1, 2011.
- [4] Jędrzejowski, J, *Obliczanie tłokowego silnika spalinowego*, Wydawnictwa Naukowo-Techniczne, Warszawa 1984.
- [5] Gawande, S. H, Navale, L. G., Nandgaonkar, M. R., Butala, D. S, Kunamalla S., *Detecting Power Imbalance in Multi-Cylinder Inline Diesel Engine Genset*, Journal of Electronic Science and Technology, Vol. 8 No. 3, September 2010.

